

Symbol Key

- ETC Source4 50deg
- Altman 65 6in Fresnel
- ETC Source4 PAR WFL
- Ocean Optics SeaChanger

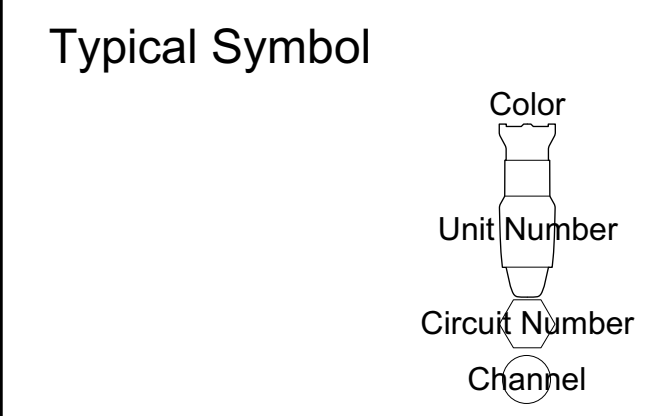

Notes:

House lights not on plot
 Dimmer: 36
 Channel: 101

Seachanger Address:
 SL: 101
 Cen: 105
 SR: 109

- Power for Seachanger to come from booth
 Circuits: O2; Q2; L1
- Fresnels on Pipe C should have barn doors
- All fresnels should be hung at full spot
- Source fours should be hung sharp
- S4 Par Beam Axis run SR/SL
- Twofer/Threefer as possible
- Barn doors should be available for focus
- All lights should start down for focus

Production: Just One More Hand	
Show Dates: February 14th thru 18th, 2018	
Produced By: Stockton University	
Venue: Experimental Theatre	
Drawing Title: Light Plot	
Lighting Designer: Timothy Simon	
Directors: Pam Hendrick & Ryan Gorman	
Scale: 1/2" = 1'	Drawing Number: 1 of 1
Version: Two	